

terra forno

HAND CRAFTED
WOOD & GAS
FIRED OVENS



ABOUT US

Terra Forno Ovens - A product from **DIFAB Engineering Pvt Ltd**. At DEPL, we manufacture exquisite hand crafted wood and gas fired ovens - for restaurants and residences alike.

Our ovens are prefabricated, refractory and modular, designed for fast and accurate assembly, with superior efficiency. The system consists of interlocking refractory components which adhere together with masonry mortar and are insulated with the best materials, resulting in a oven which is very hot on the inside, while retaining a cool surface and safe to handle from the outside.

The burner systems are imported from Italy, providing the best in class gas firing, well suited for wood fired ovens with full flame control and pleasing aesthetics. Our burners are well suited for vent-less cooking, by incorporating safety features like thermocouple controlled pilot flame valve.

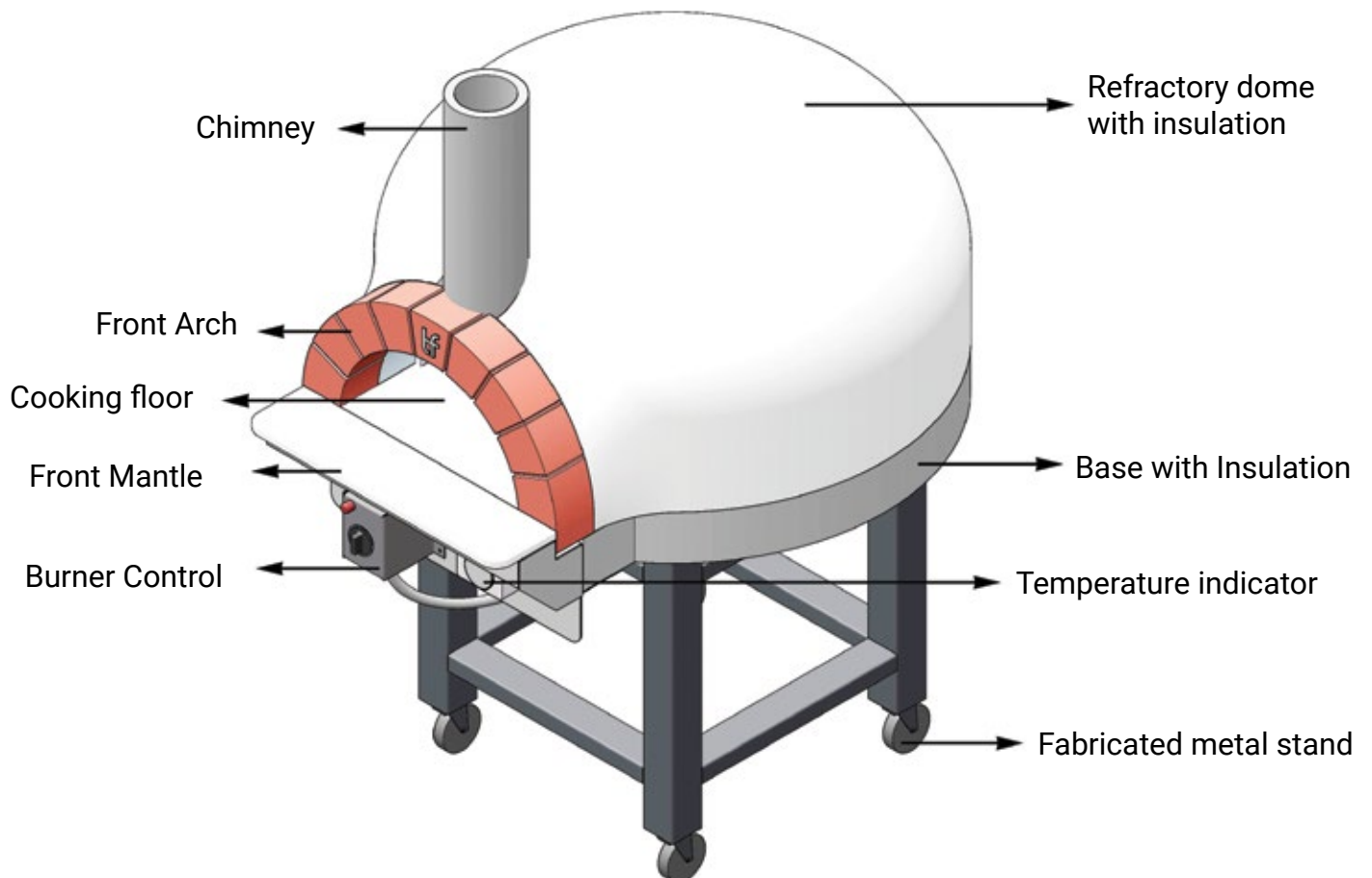

Typical arrangement of the oven

PRODUCTS AND SERVICES

We provide a turnkey solution to support your business or hobby. Our team of engineers and chefs will support you in choosing the right oven for your needs, as well as train you to cook the perfect Italian style pizzas, including a host of recipes and techniques.

OVEN
MANUFACTURE
AND SETUP



*We give you
the full solution!*

INSTALLATION
AND TRAINING



*Home
enthusiast?*



OVEN
MAINTENANCE
AND SERVICE

*Restaurant
business?*



COOKING
AND
TRAINING

NAPOLI SERIES

DEPL manufactures ovens suitable for both restaurants and home enthusiasts alike. Contact us for a detailed know how of the models available and how it will suit your line of work.

NAPOLI SERIES - For the Professional

Features:

- This oven has higher thermal mass, resulting in longer heat up times before firing, but excellent heat retention ability which helps in everyday firing by saving on cold start fuel costs. Mainly suited for restaurants / caterers
- Can be customized with a variety of facade options
- Gas burner option available



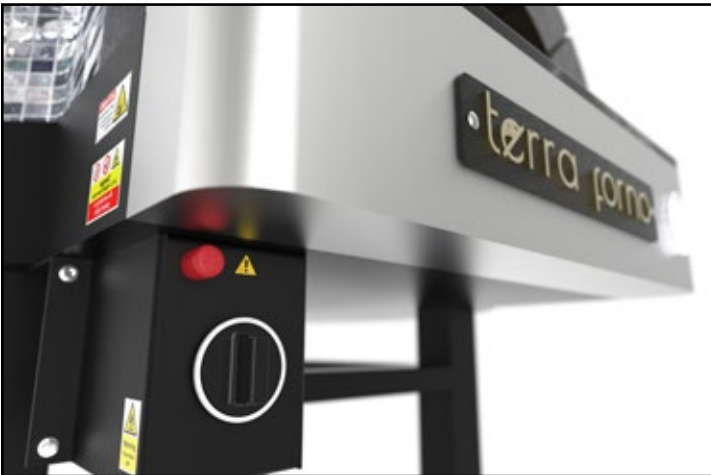

Stainless steel mantle / Burner control box



Underfloor burner

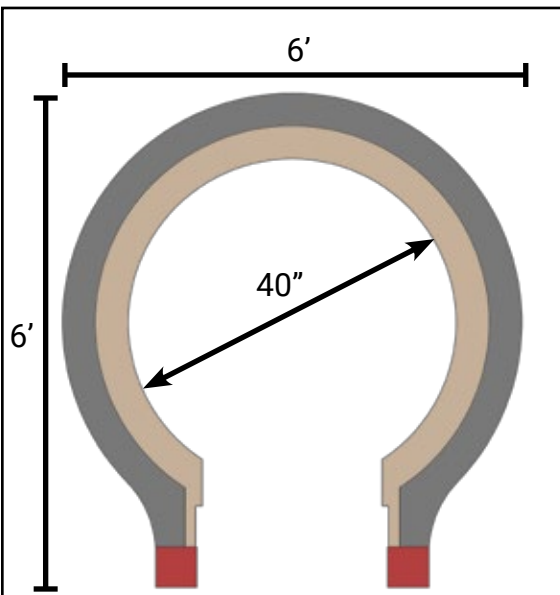

Oven footprint and dimensions

FEATURES - NAPOLI	
Cooking floor size	40 " diameter
Cooking capacity	5 to 6 x 9" Pizzas
Footprint	6' x 6' (1800 mm x 1800 mm)
Cooking time	2 minutes / pizza
Burner gas consumption (Gas models only)	Average approx. 1.5 kg / hr
Construction options	Dome or Steel Enclosure
Facade options	Mosaic tiles, Stucco , Stainless steel
Color options	Variety of colors available
Mantle	Stainless steel + Granite
Fuel type	LPG / Natural gas / Firewood only / Firewood - LPG combo
Accessories	<ul style="list-style-type: none"> • Peel • Temperature Gun • Front door • Night Door - Insulated • Ash guard for burner • Burner cap
Net Weight	1350 kg approx
Floor to Mantle height	4' approx

VERONA SERIES

VERONA SERIES - For the Hobbyist / Home / Residential

Features:

- This oven has slightly lower thermal mass, resulting in shorter heat up times before firing, and slightly lesser heat retention
Mainly suited for homes / residential installation / small cafe
- Can be customized with a variety of facade options
- Gas burner option available





Stainless steel mantle / Burner control box



Burner in cooking chamber / Granite mantle

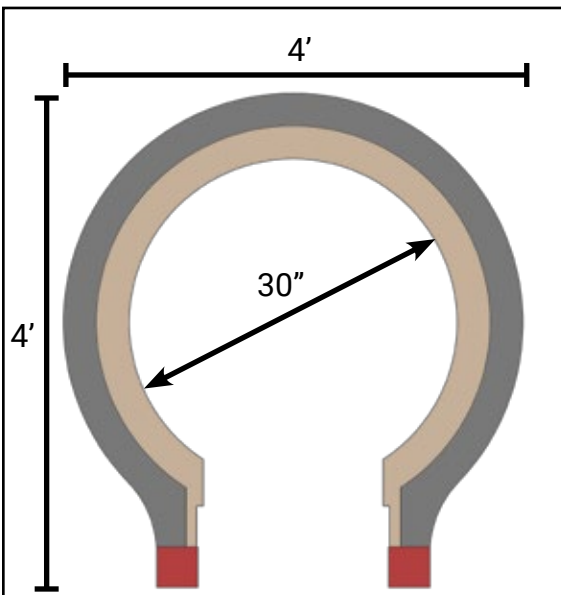

Oven footprint and dimensions

FEATURES - NAPOLI	
Cooking floor size	30 " diameter
Cooking capacity	2 to 3 x 9" Pizzas
Footprint	4' x 4' (1250 mm x 1250 mm)
Cooking time	2 minutes / pizza
Burner gas consumption (Gas models only)	Average approx. 1.5 kg / hr
Construction options	Dome or Steel Enclosure
Facade options	Mosaic tiles, Stucco , Stainless steel
Color options	Variety of colors available
Mantle	Stainless steel + Granite
Fuel type	LPG / Natural gas / Firewood only / Firewood - LPG combo
Accessories	<ul style="list-style-type: none"> • Peel • Temperature Gun • Front door • Night Door - Insulated • Ash guard for burner • Burner cap
Net Weight	900 kg approx
Floor to Mantle height	4' approx

A FEW FACTS OF THE WOOD FIRED OVEN

The wood fired oven is a time tested oven, designed to bake and cook to perfection the best pizza and breads.

Benefits of cooking in a wood fired oven:

- Wood fired ovens can cook pizza really quickly! As compared to conventional ovens, which max out at 250 °C, a wood fired oven can reach 450-500 °C
- The perfect Neapolitan pizza cannot be cooked in an electric oven. High temperatures occur only in the wood fired brick oven, ideal for cooking.
- Mozzarella cheese cannot handle low cooking temperatures. The only way to cook it properly is in a high heat environment in a traditional brick oven.
- High thermal conductivity of steel ($\sim 50 \text{ W/mK}$) vs that of firebrick ($\sim 0.5 \text{ W/mK}$) proves that conventional ovens with steel parts have a tendency to burn the toppings even before the dough and other ingredients can even cook. A traditional brick oven does the exact opposite, uniformly cooking your pizza to perfection!
- Traditional ovens store the energy in them by way of their appropriate thermal mass, and cook the pizza by way of conduction, convection and radiation. This makes the pizza cook thoroughly and well.

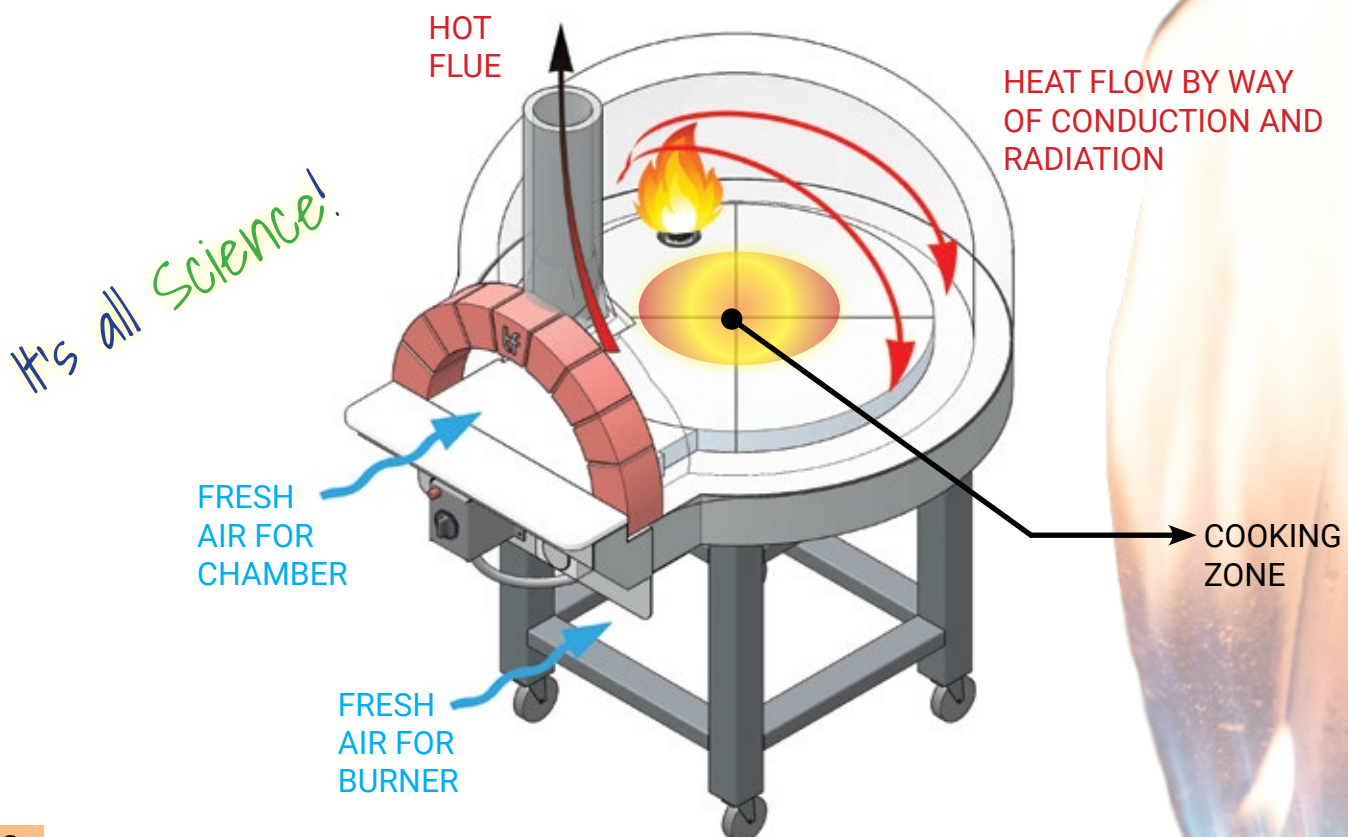

Clean fuel! - you can
always add firewood
too!

BURNER FEATURES

A SILENT ATMOSPHERIC BURNER - Terra Forno incorporates burners imported from Italy into its ovens.

Features:

- A silent , atmospheric burner
- Low pressure , low consumption burner
- Works on LPG / Natural gas
- Can be used along with firewood in the oven
- Safety features like thermocouple controlled solenoid valves
- Pilot flame in the burner for safe operation
- Manual / Automatic operation mode available.

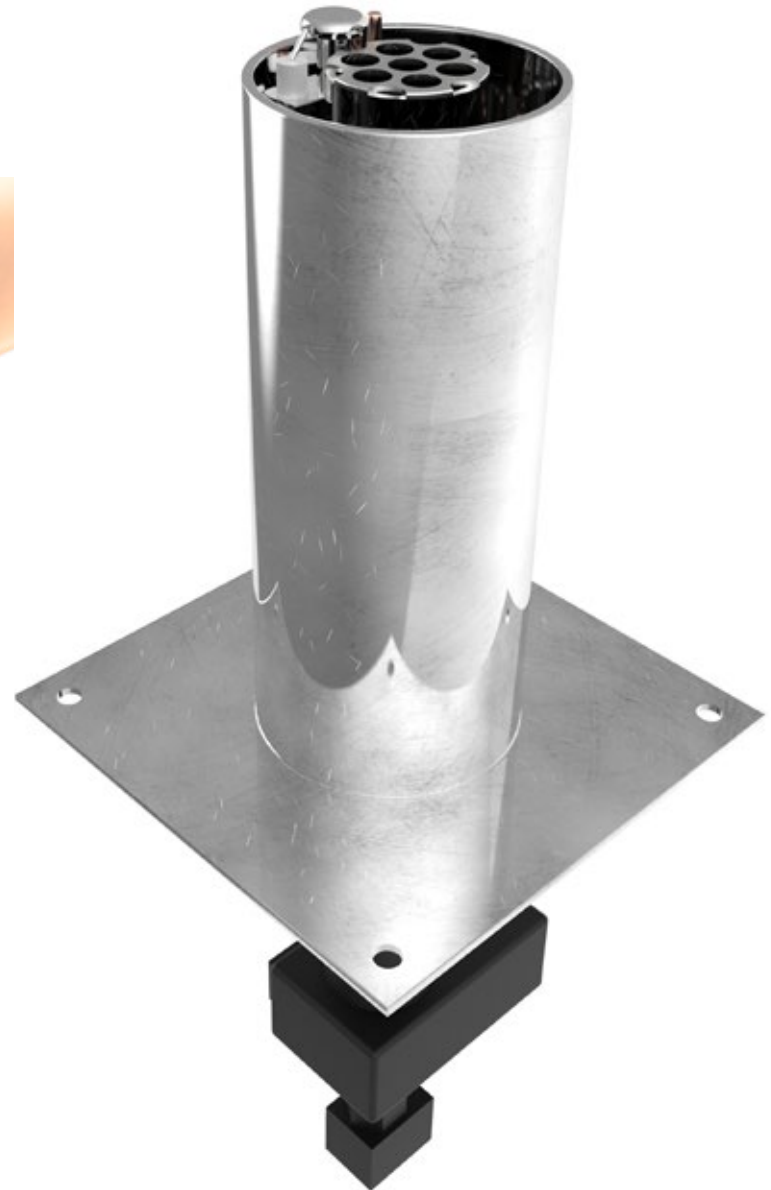

→ Burner main body

→ Pilot assembly
with safety
thermocouple
and sparking

COOKING AND TRAINING

*Upskill yourself!
(or your team!)*

Every oven purchased includes the exhaustive training package for you or your team of chefs.

Features:

- **Oven management** - learn the right way of managing the fire and temperature in your oven
- **Cooking** - Learn the art of cooking the perfect Italian pizza and other dishes for your oven. This includes dough making, sauces etc.
- **Packages for your Chefs / staff** - In case your staff needs a refresher course or you have hired new hands for your restaurant.
- Cooking classes for groups of home enthusiasts also can be organized.



*Make it yours!
customize it!*

CUSTOMIZATIONS

OVEN FORM AND FACADE - Choose your oven's form and facade from a variety of options



COLORS AND MATERIAL - Choose suitable colors, patterns and designs and customize your oven!

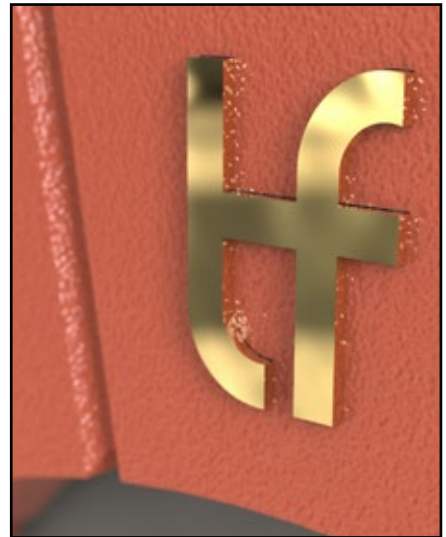

ACCESSORIES

Choose from a wide variety of optional and essential accessories for your oven.

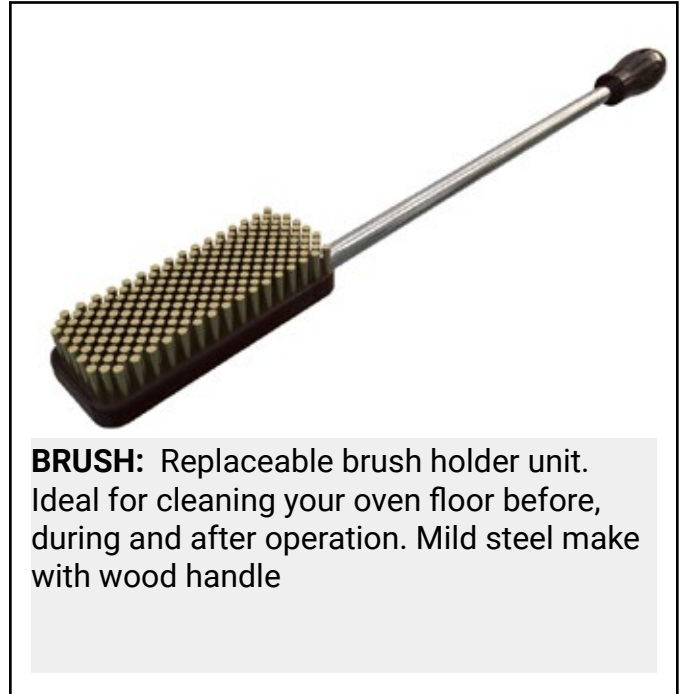

ACCESSORIES



BURNER CAP: Use when burner is not in use to prevent ash and other debris from entering the burner. Stainless steel make



FRONT DOOR: Use when oven is in operation, to prevent hot flue from reaching operator.



INSULATED NIGHT DOOR: Use when oven and burner is switched off, after working hours. To prevent heat loss from chamber. Best for commercial. Stainless steel make



WOOD HOLDER: Use to place firewood when cooking along with burner. Keeps floor tidy and makes room for cooking. Stainless steel make

CUSTOMER

CUSTOMER : DYP HOSPITALITY PVT LTD
PROJECT : SAYAJI HOTEL , KOLHAPUR
OVEN : Napoli 40" - Wood + Gas combo



IMAGE GALLERY





Terra Forno Ovens

Off: DIFAB Engineering Pvt Ltd
768/30 RPD College Road
Hindwadi
Belgaum, Karnataka
India 590011



+91 91083 12525



info@difab.co.in



www.terrafornoovens.com